

AAADM

American Association of Automatic Door Manufacturers

AUTOMATIC FOLDING DOOR

OWNER'S MANUAL

Distributed by:

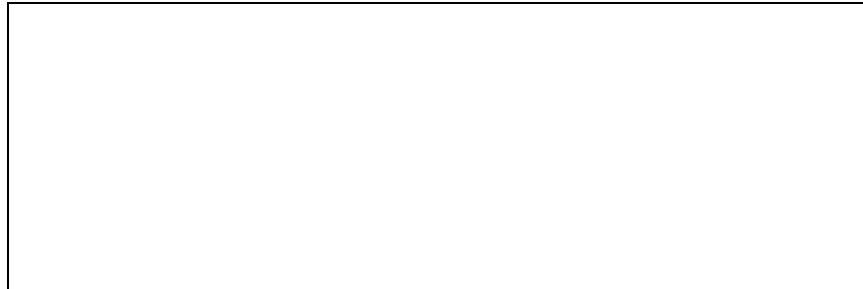

Section	Contents	Page
Caution		2
To Our Customers		3
Service Availability		3
Compliance with Safety Standards		3
What You Should Know		4
Daily Safety Check		5
Operation		8
Limited Warranty		8



CAUTION

An Improperly Adjusted Door can cause injury and/or equipment damage.

Inspect door operation daily using safety checklist in owner's manual and at door.

Have door adjusted as described in Owner's Manual.

Safety devices should be in place and operational.

Have door inspected at least annually by an *AAADM* certified inspector.

In the following manual, the word:

Caution means that injury or property damage can result from failure to follow instructions.

Note is used to indicate important steps to be followed or important differences in equipment

To Our Customers

The purpose of this manual is to familiarize you with your automatic door system. It is essential that you "know your system" and that you recognize the importance of maintaining your door system in compliance with the industry standards for safety.

It is your responsibility, as owner or caretaker of the equipment, to inspect the operation of your door system on a daily basis to ensure that it is safe for use by your invitees, customers, or employees.

This manual will provide you with a description of the operation and maintenance requirements of your door. It also provides the instructions for the *Daily Safety Check*.

Should the door fail to operate as prescribed in the *Daily Safety Check*, or at any other time for any other reason, **do not attempt to repair or adjust the door**. Call an AAADM Certified service technician. These technicians are trained to service your door in accordance with applicable industry safety standards.

Service Availability

Automatic door products are distributed through a nationwide network of authorized automatic door suppliers for sales, installation, and service.

Should you need service on your door system, consult the respective door manufacturer or its authorized representative.

Compliance with Safety Standards

Your door system was designed to the latest operating and safety standards. In order to ensure the continued safe operation of your door, it is important that:

- Your door system be maintained in compliance with the standards of the industry.
- Proper signage and labels be applied and maintained on your doors. If signage is removed or cannot be read, request replacement when calling for service.
- All doors should be checked by an AAADM certified inspector at least annually.

AAADM, the American Association of Automatic Door Manufacturers, has established a program to certify automatic door inspectors. Through this program, the inspectors are trained to check your door systems for compliance with the American National Standards Institute standard ANSI/BHMA A156.10.

What You Should Know

Be sure that an automatic door supplier has provided the following for each door:

1. Instruction on how to conduct the *Daily Safety Check* * (by walk-through example).
2. Location of function switches and instruction in their use.
3. Circuit breaker or main power disconnect location for each door system.
4. Number to call for service or questions about your system if you are uncertain of any condition or situation.
5. AAADM inspection form or a work order signed by an AAADM certified inspector.
6. A completed Annual Compliance Inspection label, located at the bottom of the Safety Information label affixed to the door.
7. Warranty information for each door.

Note: If there are any problems, or if you are unsure about the safe performance of the door, **discontinue door operation immediately** and secure the door in a safe manner. Call your authorized automatic door professional for repairs.

* **Note:** AAADM Daily Safety Check videos are available. Contact an automatic door supplier or AAADM.

Folding doors are installed in a large number of combinations:

- Doors Fold In - Swing Out in Emergencies
- Doors Fold Out - Swing Out in Emergencies
- Single Folding (2-panel) or Folding Pair (4-panel)
- One-Way Traffic or Two-Way Traffic
- Activated by Floor Mat, Sensors, or Push Switches

They always require the following safety items:

- A Safety Zone to cover the area the doors travel.
- Guide Rails on the fold side of the doors (unless a wall is in the same position).

This manual presents a broad view of the most popular types. It covers the basic principles to check your doors for safety. If you have any questions, call your automatic door supplier or the manufacturer of the equipment.

Daily Safety Check(All figures and diagrams are for purposes of illustration only)

Perform the following safety checks *daily* on each automatic folding door to ensure your customers' safety and your own protection. Perform these tests while traffic is restricted from all detection and sensing zones.

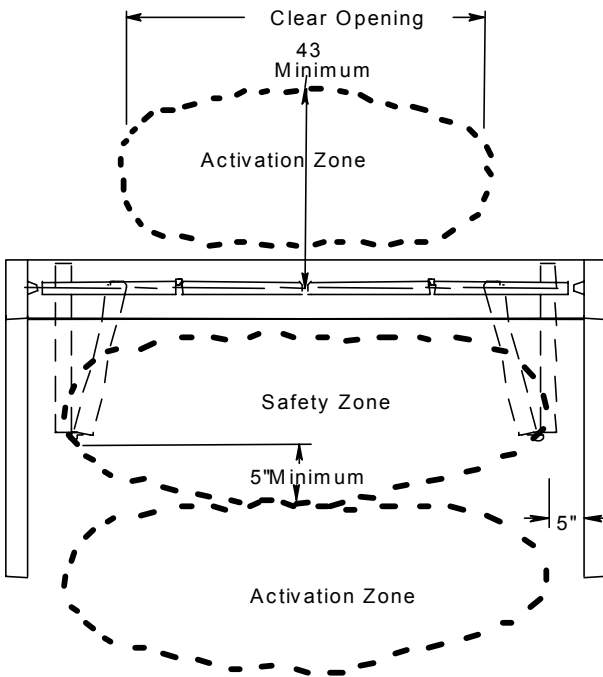

Figure 1

Sensor Activation/Presence Detection Safety

1. Check electronic sensor by walking toward the door opening at a moderate speed. The door should start opening when you are about 4 feet from the door, should open smoothly, and stop at the fully open position without impact. Move slowly through the door opening (6 inches per second). The door should remain open. If door is used for two way traffic, repeat from other side.
2. Step out of the sensor zone. After a brief time delay (at least 1½ seconds) the door should close smoothly and should close fully without impact.
3. Approach the fold side of the door first, then have someone else approach the opposite side of the door. As long as you are in the safety area (fold area) of the door, it should not open. (See Figure 1)

Caution: If safety sensor is not working, door may open toward you without stopping.

4. Crouch in the door opening for at least 4 seconds. The door should not close.

Floor Mat Activation/Floor Mat Safety

1. Step on the "opening" (activating) mat.
2. It is necessary to have a safety mat covering the entire area over the fold travel. Step through the doorway onto the safety mat and remain motionless for 4 seconds. The door should remain open. Repeat at several locations on the mat. (See Figure 2)
3. Step off the safety mat. After a brief time delay (at least 1½ seconds) the door should close smoothly and without impact.
4. With the door closed, step on the safety mat on the fold side. Have someone step on the activating mat. Door should remain closed as long as someone remains on the safety mat.

Caution: If safety mat is not working, door may open toward you.

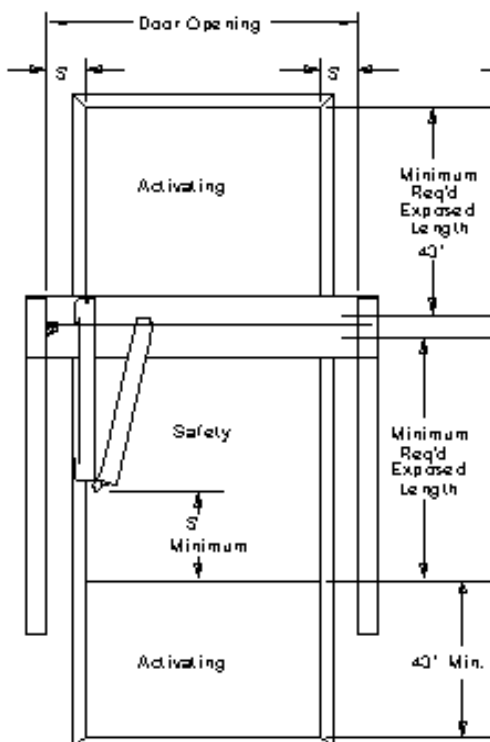

Figure 2

5. Check the mat molding and threshold. It should be complete and secured with all required screws.



Figure 3



Figure 4



Figure 5

General Safety

Pay attention to the following general safety items and conduct checks periodically where noted.

1. Force Force to prevent the door from closing should not exceed 15 pounds. This can be measured with a force gauge.
2. Breakout Stop. Center pivoted folding doors may be supplied with an emergency breakout stop or switch that will allow the door to swing open. Call your automatic door supplier for details.

When the door is pushed into the breakout mode, check that door will not activate.

3. Signage. The door should have decals properly displayed as follows at a height 58 inches, ± 5 inches from the floor to the centerline of the sign (unless otherwise noted). The decal shall be a minimum of 6 inches in diameter (unless otherwise noted):

- A. If one way traffic, an arrow (See Figure 3) shall be visible from the approach side of a swinging door, mounted on the door. The decal shall have a green circle surrounding a black arrow on a white background.
- B. If one-way traffic, an international "DO NOT ENTER" decal (See Figure 4) shall be visible from the side that would swing toward pedestrians attempting to travel in the wrong direction. The decal shall have a red circle with the wording, "Do Not Enter", in white letters in the red circle.
- C. Doors serving two-way traffic shall be marked with a decal, visible from both sides of the door, with the words "Automatic CAUTION Door". (See Figure 5) The letters in the words "Automatic Door" must be at least $\frac{1}{2}$ inch high. The decal shall be made with black lettering on yellow background.
- D. AAADM safety information label should be affixed on the door frame in a protected, visible location. If you need additional decals or labels for automatic doors, call an automatic door supplier.

**AUTOMATIC DOOR
ACTIVATE SWITCH
TO OPERATE**

Figure 6

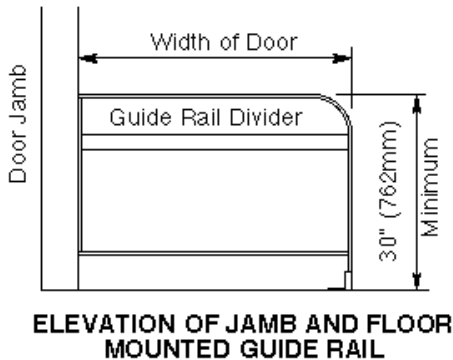

Figure 7

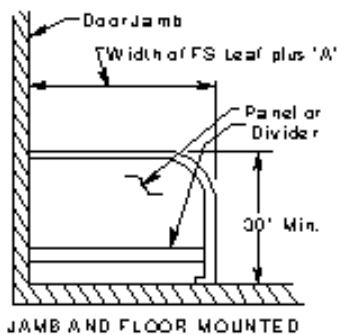

Figure 8

4. Activating Switch. (Knowing Act) Doors equipped with a manual activating switch shall hold fully open for a minimum of 5 seconds before closing.

Doors equipped with a manual activating switch shall have a decal as follows: "Automatic Door. Activate Switch to Operate." The decal should be visible from both sides of the door or the side with the knowing act switch if there is only one. (See Figure 6)

5. Guide Rails. Check that two guide rails or other barriers or separators are present on the fold side and firmly anchored. (See Figures 7, 8, 9)
6. Housekeeping. Check the door area for tripping or slipping hazards.

Check all door panels for damage. Make sure that all hardware and overhead covers are properly secured. There should be no bulletin boards, literature racks, merchandise displays, or other attractions in the door area that would interfere with use of the door or invite people to stop or stand in the door area.

7. Traffic Patterns. Observe traffic patterns. Plan routing so people enter and exit in a straight approach, directly toward the center of the door opening.
8. Finger Guard. Inspect finger guard to see that it is secure and in good repair. (See Figure 9)

IF YOU HAVE A PROBLEM, TURN OFF THE DOOR OPERATING EQUIPMENT AND CALL AN AUTOMATIC DOOR SUPPLIER TO MAKE PROMPT REPAIRS.

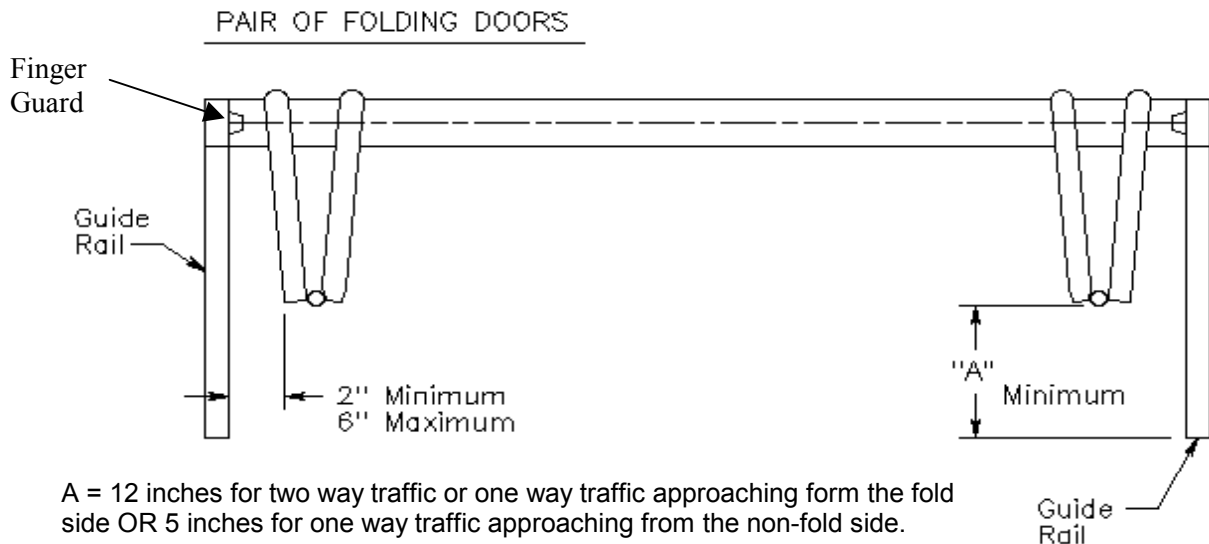

Figure 9

Operation

(This section to be added by Company.)

Warranty

(This section to be added by Company.)